

Chapter 2

Flight 77: Was it really the aircraft that struck the Pentagon?

From the book, "*The New Pearl Harbor: Disturbing Questions about the Bush Administration and 9-11*," by David Ray Griffin

"Who are you going to believe?
Me, or your own two eyes?"
Groucho Marx

Outline of Flight 77 presentation

- The story so far
- Flight 77
 - Timeline
 - Photographic evidence of Pentagon damage
 - The security camera video
 - Who was the pilot, and where was the Pentagon hit?

★ Review of the last presentation

- Failure to intercept flights 11 and 175, in violation of published operating procedure
- Intercepts ordered from distant bases, too late and too slow
- Evidence of possible demolition of World Trade Center 1 & 2
 - Reversal of expectations - 2nd tower hit fell first
 - Extremely small debris
 - Seismic evidence consistent with demolition
 - Failure to investigate cause of collapse
- Apparent controlled demolition of World Trade Center 7, otherwise it is the only steel frame building in history to collapse solely due to fire

FAA background

- Consider that an aircraft emergency exists when there is unexpected loss of radar contact and radio communications with any aircraft.
- If an aircraft deviates more than 15 degrees or two miles from a flight course, it is an emergency.
- If there is any doubt that a situation constitutes an emergency or potential emergency, handle it as though it were an emergency.

Response to an emergency

- The FAA is to notify NORAD
- NORAD dispatches fighter jets to the aircraft in question - intercepts
- Intercept is an automatic and routine response to a possible emergency
- Prior to 2001 intercepts required no upper level approval.
- In 2001 there were 67 such intercepts prior to 9-11

Flight 77 timeline

- 8:20 am American Airlines flight 77 leaves Dulles Airport in Washington, DC
- **8:46 am** Significantly altered course
- **8:50 am** Resumed original course, but radio contact lost
- **8:56 am** Transponder turned off, and plane disappeared from Indianapolis air traffic control screens
- 9:09 am Air traffic control warned that plane may have crashed in Ohio
- 9:24 am FAA notifies NORAD of flight 77 hijacking

Flight 77 timeline

- 9:25 Air controllers at Dulles report a fast moving plane apparently heading toward the White House
- 9:27 Plane reported 50 miles from Washington
- 9:27 am NORAD scrambles planes from Langley, 130 miles from Washington
- 9:33 Radar showed aircraft crossing the Capitol Beltway
- 9:35 Plane flies over the Pentagon at 7000 feet of altitude, corkscrews 270 degrees
- 9:38 Aircraft impacts the Pentagon from the west
- 9:53 am Langley F-16's arrive in Washington

Path of Flight 77



Problems with the timeline

- At 8:43 am latest, all traffic control knew of at least two other hijackings - why delay in reporting flight 77 as possible hijack until 9:24 am?
- Why did flight 77 fly uncontested for almost 50 minutes after radio contact was lost?
- Why were F-16's dispatched from Langley, when Andrews AFB had fighters 10 miles away?
- Why did it take 20 minutes for F-16's to cover 130 miles from Langley?
- Turning off a transponder doesn't make plane invisible - only ID tag is missing on radar screens

The Official Story on what hit the Pentagon

- Flight 77, an 80 ton Boeing 757, hit the Pentagon
- Hijacker pilot was Hani Hanjour
- Plane disintegrated on impact
- Resulting fire destroyed plane thoroughly

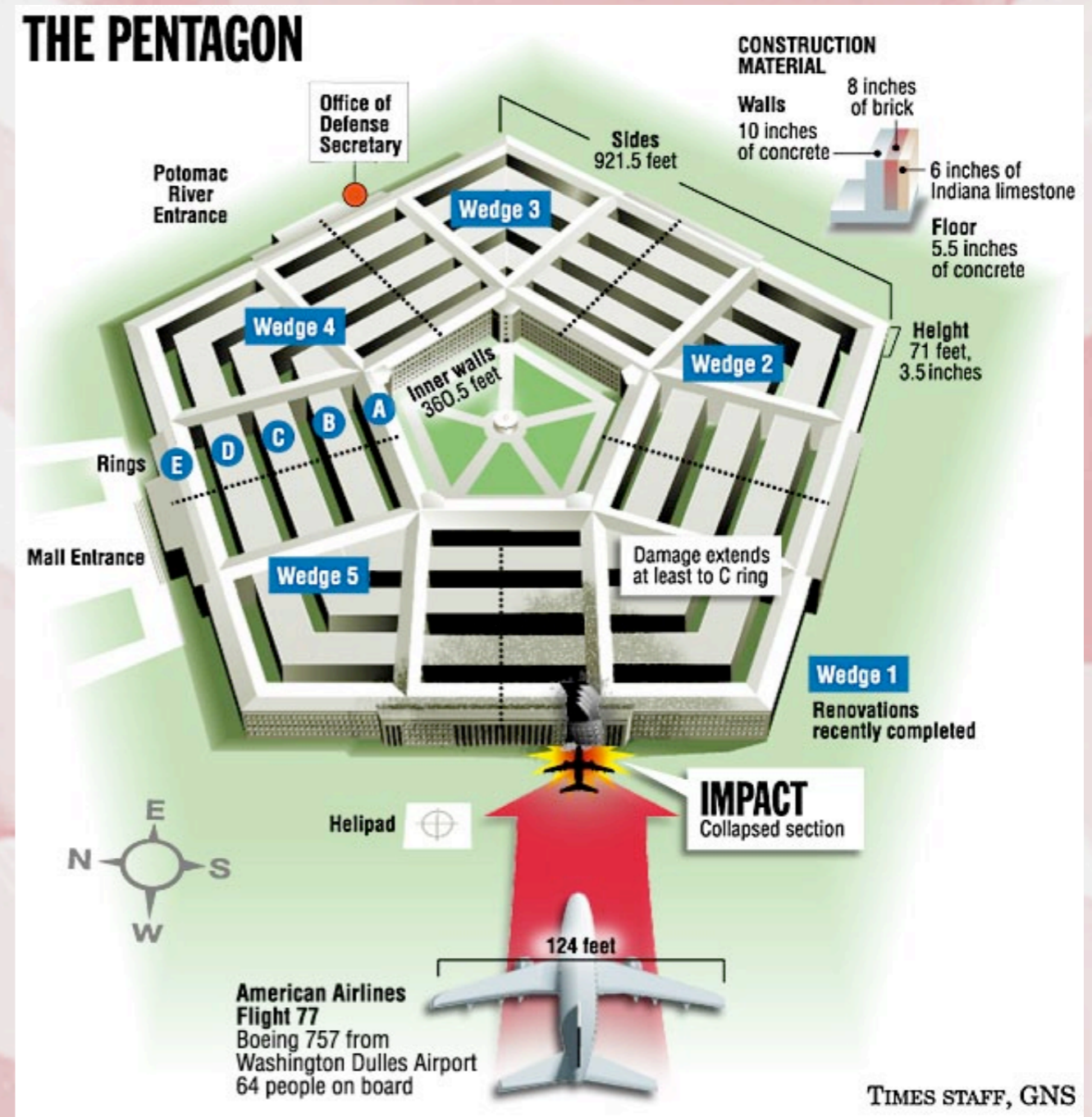

Historical crash photos - Lockerbie

- Pan Am 103 broke up when terrorist bomb exploded in baggage compartment
- December, 1988
- Aircraft was a Boeing 747
- Note size, condition of engine that impacted a street
- Note size of huge gully created



Historical crash photo - Siberia

- Tupolev 154M passenger jet
- Went into “flat spin”, crashed into ground, burned
- Nearly all of plane destroyed
- Note intact tail section



Photo of the collapsed Pentagon



Associated Press photo



Dept. of Defense photo

DEFEND AMERICA

U.S. Department of Defense News About the War on Terrorism

Government

[FirstGov](#)

[EPA](#)

[FAA](#)

[FBI](#)

[FEMA](#)

[Homeland Security](#)

[Justice Department](#)

[State Department](#)

[Treasury](#)

Department

[White House](#)

[War on Terror Sites](#)

Military

[DefenseLINK](#)

[Army](#)

[Navy](#)

[Air Force](#)

[Marines](#)

[Coast Guard](#)

[Reserve Affairs](#)

[Army Reserve](#)

[Navy Reserve](#)

[Air Force Reserve](#)

[Marine Reserve](#)

[Coast Guard](#)

Reserve

[National Guard](#)

[Air National Guard](#)



The Pentagon in flames moments after a hijacked jetliner crashed into the building Sept. 11, 2001. Photo by Cpl. Jason Ingersoll, USMC

[Home](#) [Photo Gallery](#) [Next](#)

Marine Cpl. Jason Ingersoll photo #1



Marine Cpl. Jason Ingersoll photo #2



Dimensions of a Boeing 757

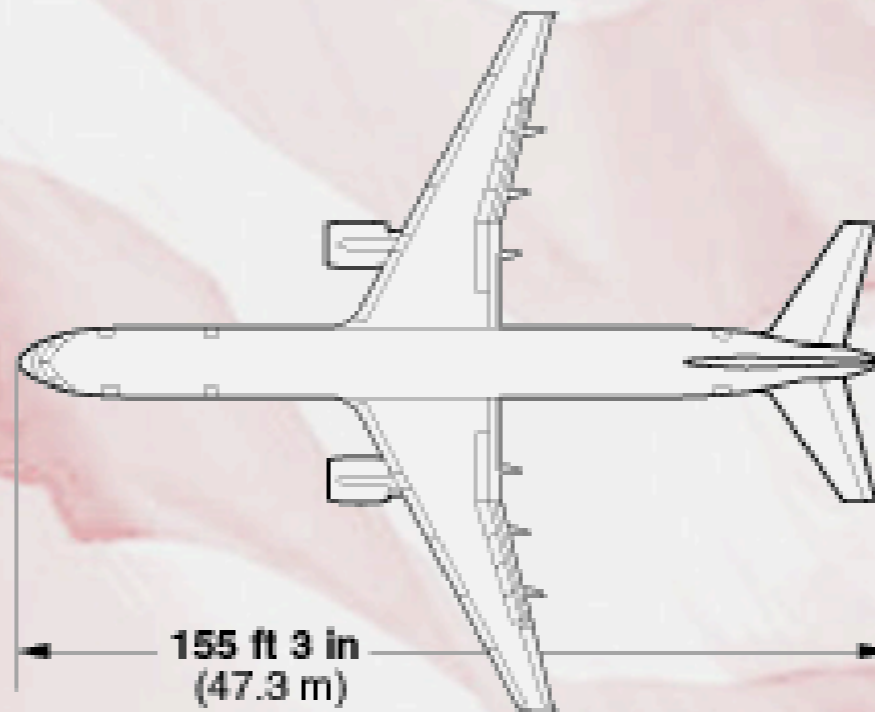
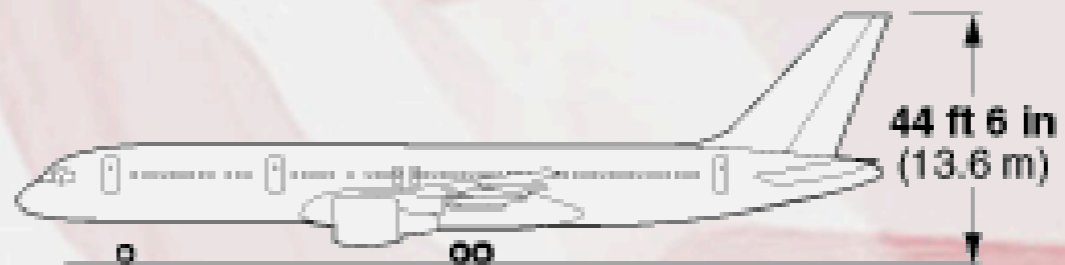
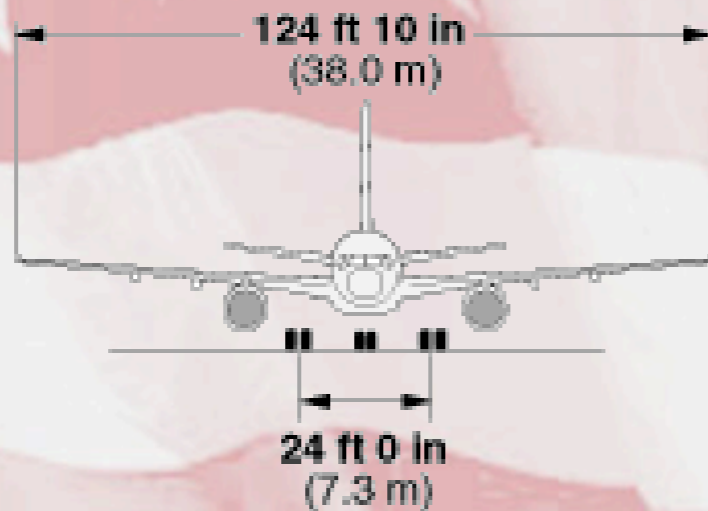

Annotated composite photo



- Expect multiple holes from engines - none seen
- No sign of damage from tail
- Entry hole at most 18 feet diameter, with 96 foot damage width

Essence of “No-Boeing” case

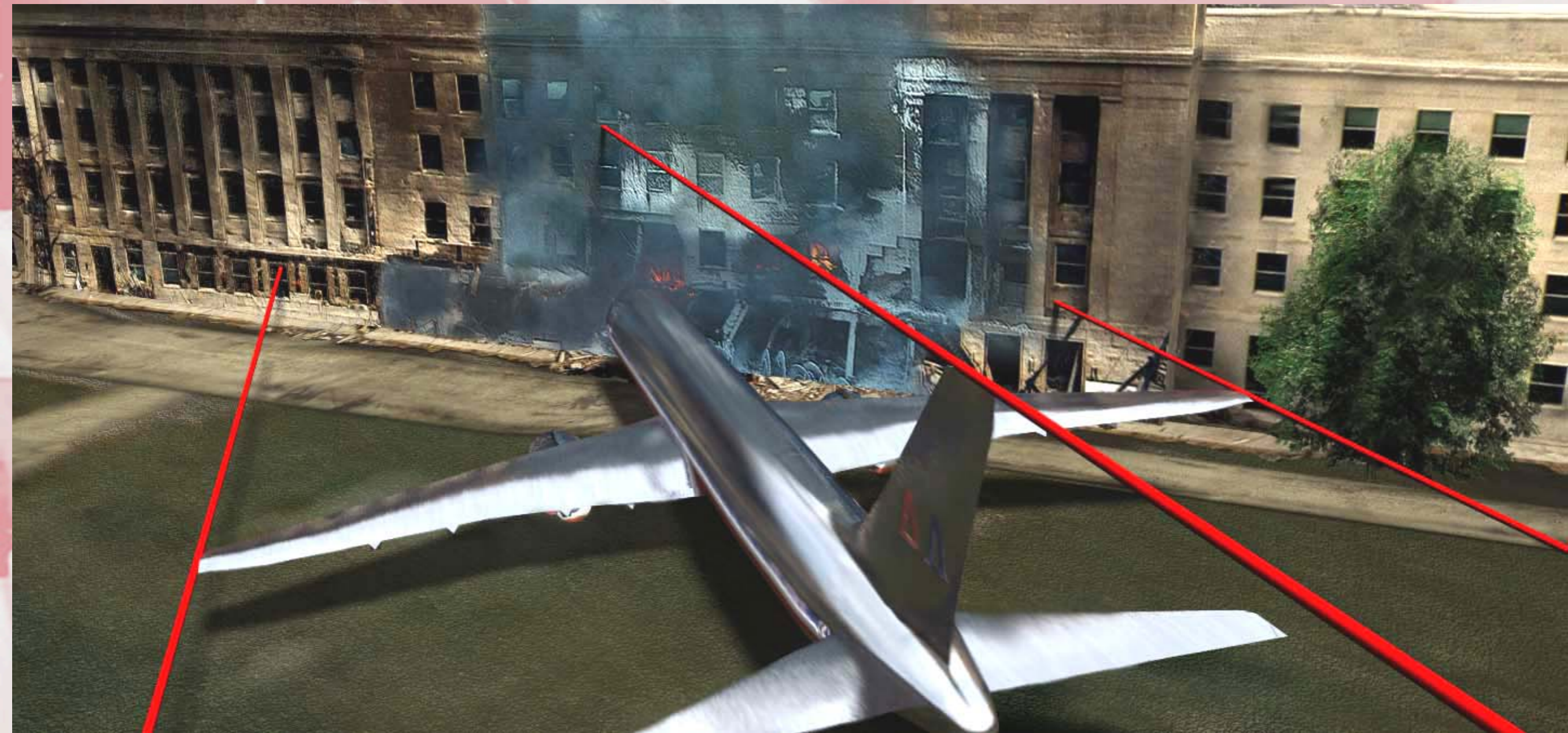

Sole recognizable exterior wreckage



Interior wreckage

- Supports official story
- Only few small pieces were photographed
- Access controlled, so photos are from FEMA



BOEING
757
PARTS CATALOG (MAINTENANCE)

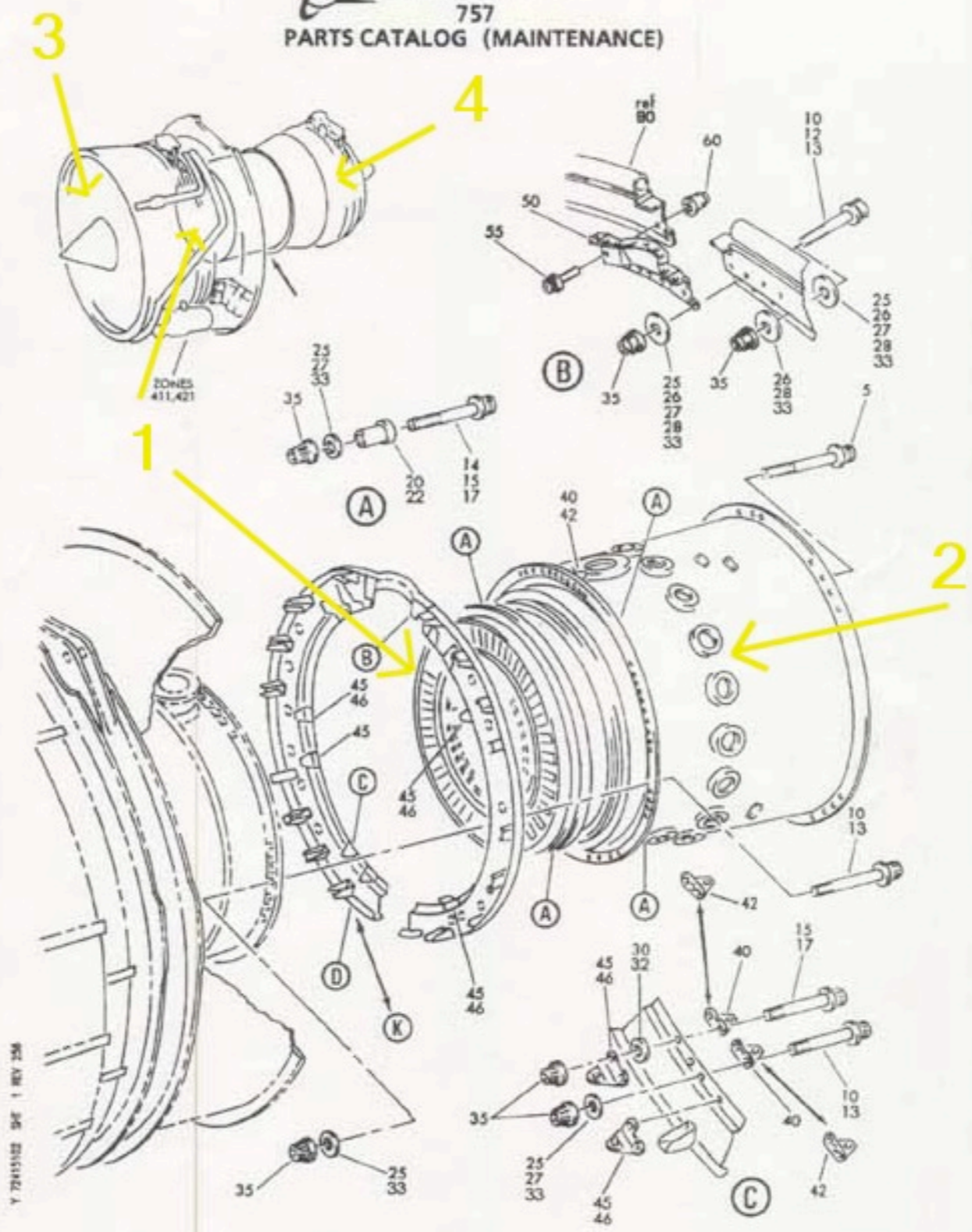

Y 7245102 SHE 1 REV 256

MODULE-NO. 4 HIGH PRESSURE SYS (RB211-535)
FIGURE 2 (SHEET 1)

72-41-51-02

JAN 28/03

72-41-51-02
PAGE 0

Small exit hole in C ring

- Nose of airliner is not hardened
- This is the 6th thick wall the plane would have to pierce
- 757 could not fit entirely within the building



Hail damage to nose cone of jetliner



Conflicting witness statements

- Witnesses in gas station, cemetery, and I-395 reported seeing low, slow 757
- One witness reported seeing two planes
- Several witnesses reported a small plane

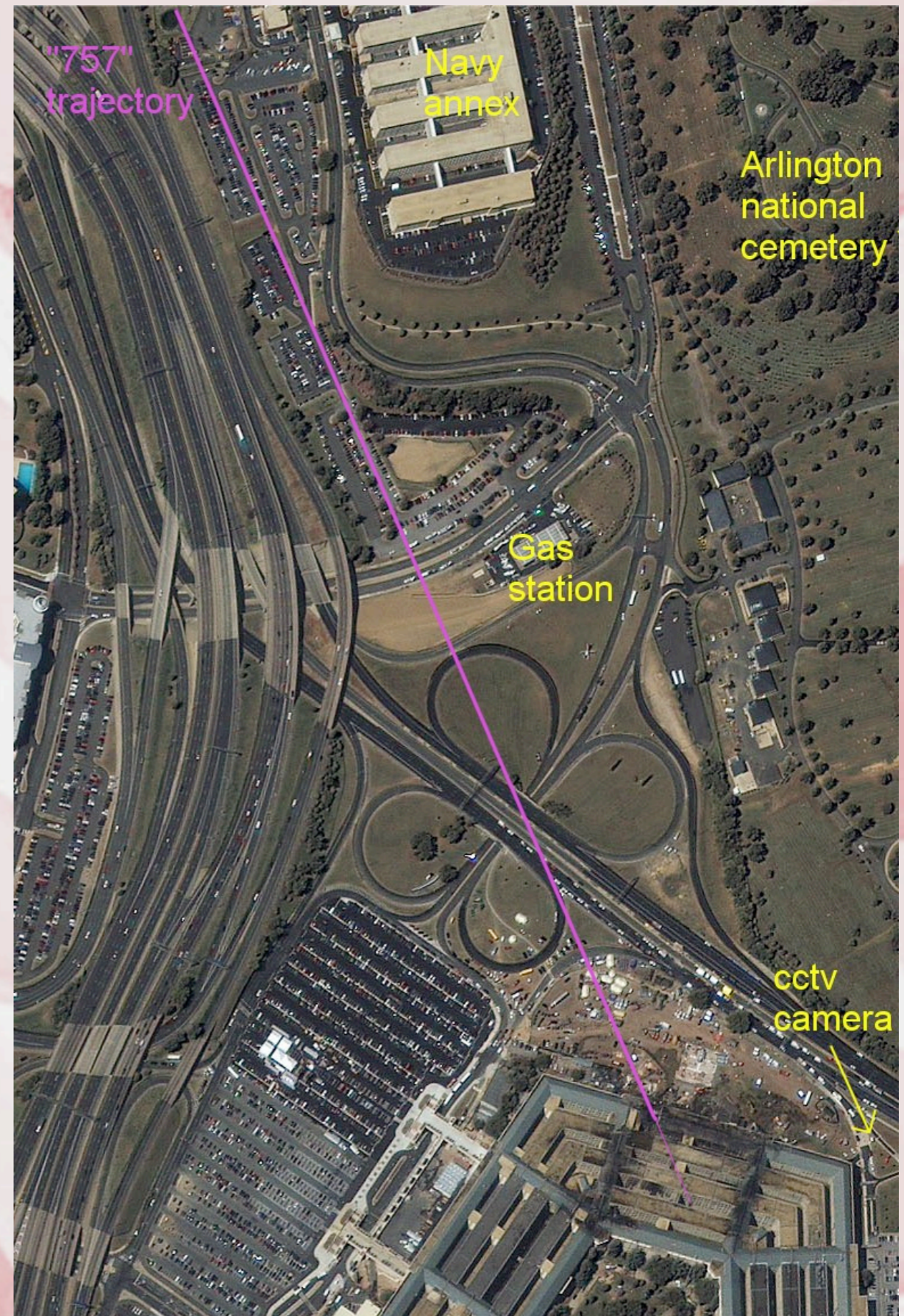

Hunt the Boeing

Question n°5



Image : Space Imaging

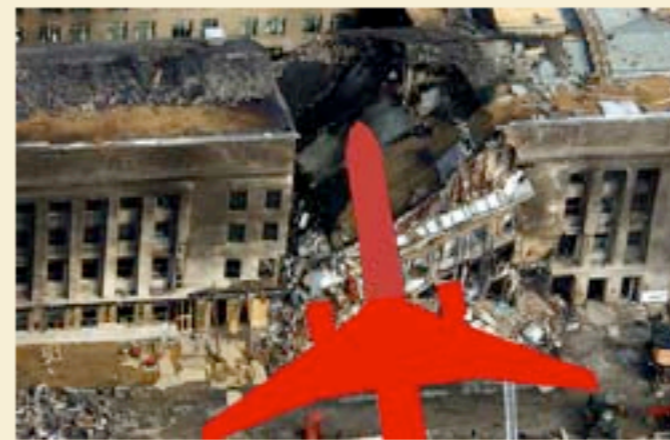

Image : U.S. Department of Defense, Sgt. Rudisill

The photographs in Question 5 show representations of a Boeing 757-200 superimposed on the section of the building that was hit.

Can you explain what happened to the wings of the aircraft and why they caused no damage?

Response to Hunt the Boeing

- security camera footage released



Security camera frame 1



Security camera frame 2



Security camera frame 3



Security camera frame 4



Security camera frame 5



Problems with security camera footage

- 500 mph jet should advance 48 feet every 1/15th of second
- No visible 757 - a 155 foot plane should appear in several frames - video is incomplete or doctored
- A very small tail is visible in frame 1 - too small for 757?
- A white smoke trail is visible in frame 2
- Initial explosion is white, not red - more consistent with explosives, not fuel

The cover-up



- Gas station attendant: "FBI arrived within minutes and confiscated video"
- Video camera tape seized from Sheraton Hotel within minutes also

Doubts about the identity of the plane

- Some witnesses reported seeing a commuter-sized plane that made a shrill noise
- All but one of the credible witnesses interviewed on the day of the attack who identified craft as flight 77 were military personnel
- Sole telephone call from flight 77 was from the wife of Theodore Olsen, President Bush's attorney in the Florida election dispute
- Dulles air traffic controller thought that the "speed, maneuverability, and way he turned" indicated a military aircraft

Did a small military plane hit the Pentagon?

- Consistent with small entry hole
- Consistent with single engine photographed
- Consistent with single exit hole
- Consistent with some witness reports of small "commuter" plane with shrill jet noise
- Researcher Dick Eastman has developed most credible theories on what happened - two plane scenario
- ... but what happened to "real" flight 77?

Hani Hanjour - stunt pilot?

- Trained at Pan Am International Flight Academy in Scottsdale, Arizona
- Marilyn Ladner, VP of Pan Am International, was quoted as saying the staff never suspected him as a hijacker, but rather regarded as a safety hazard
- Unidentified staff member: "I'm still amazed that he could have flown into the Pentagon. He could not fly at all."
- Yet, this is the pilot who supposedly performed a 270 degree corkscrew turn dropping 7000 feet to hit the Pentagon absolutely level with the first floor

Dulles flight controller Danielle O'Brien

The screenshot shows the ABC News website interface. At the top left is the 'abc NEWS.com' logo. To its right is a blue banner with the text 'Have you asked your doctor about VIOXX? Learn more at viox.com'. Below the logo is a vertical navigation menu with links for 'FEATURED SERVICES', 'RELATIONSHIPS', 'SHOPPING', 'DOWNLOADS', 'WIRELESS', 'FREE HEADLINE FEED', 'INTERACT', 'VIDEO & AUDIO', 'BOARDS', 'CHAT', 'NEWS ALERTS', and 'CONTACT ABC'. The main content area features a '20/20' logo and a photo of Danielle O'Brien. The article title is 'Get These Planes on the Ground' with a sub-headline 'Air Traffic Controllers Recall Sept. 11'. A quote from O'Brien is highlighted in a yellow box. At the bottom, there is a 'See Most Sent' button and a snippet of text about aircraft handling at Dulles International Airport.

abc NEWS.com

Have you asked your doctor about VIOXX?
Learn more at viox.com

Available by prescription

May 11, 2004

FEATURED SERVICES
RELATIONSHIPS
SHOPPING
DOWNLOADS
WIRELESS
FREE HEADLINE FEED

INTERACT
VIDEO & AUDIO
BOARDS
CHAT
NEWS ALERTS
CONTACT ABC

20/20

'Get These Planes on the Ground'
Air Traffic Controllers Recall Sept. 11
abc NEWS

Oct. 24 — It has taken six weeks, but air traffic controller Danielle O'Brien is now ready to talk about Sept. 11.

"I've sat up straight in bed many times, reliving it, reseeing it, rehearsing it," says Danielle O'Brien, who was working in the radar room at Dulles Airport during the Pentagon attack

"The speed, the maneuverability, the way that he turned, we all thought in the radar room, all of us experienced air traffic controllers, that that was a military plane," says O'Brien. "You don't fly a 757 in that manner. It's unsafe."

See Most Sent

demeanor handling aircraft at Dulles International Airport in Virginia would be put fully to the test.

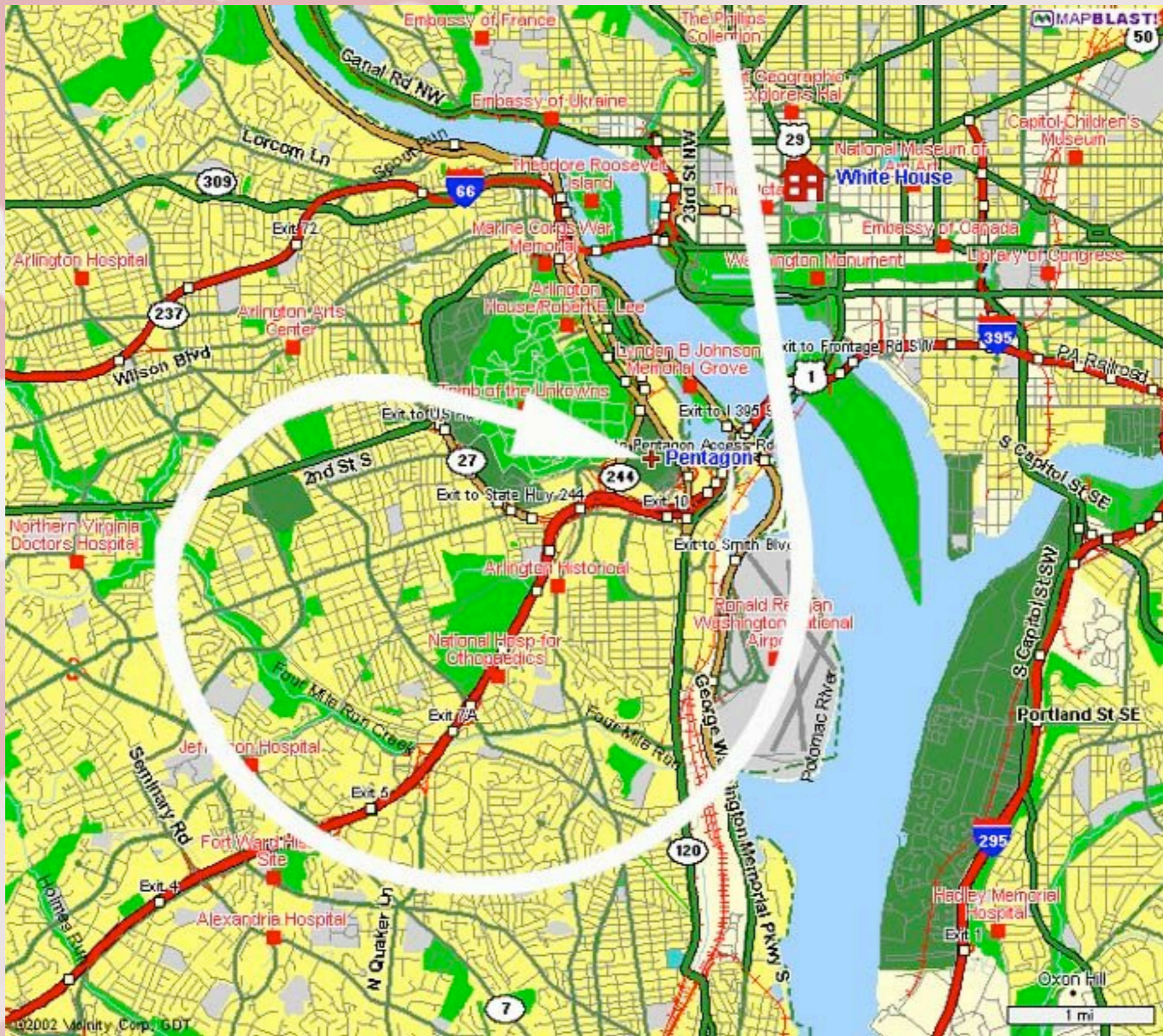

Yet, one month before attacks

Newsday
com

Newsday
com

[News](#)[Sports](#)[Business](#)[Entertainment](#)[Multimedia](#)[Marketplace](#) [NY](#)
[Newsday.com](#)

AMERICA'S ORDEAL

Tracing Trail Of Hijackers

By Thomas Frank
WASHINGTON BUREAU

September 23, 2001

Washington – Before they were hijackers, they were suburbanites.

They roomed
adult book
11. The hij
recently he
flight scho

"They did r
hijackers h

At Freeway Airport in Bowie, Md., 20 miles west of Washington, flight instructor Sheri Baxter instantly recognized the name of alleged hijacker Hani Hanjour when the FBI released a list of 19 suspects in the four hijackings. Hanjour, the only suspect on Flight 77 the FBI listed as a pilot, had come to the airport one month earlier seeking to rent a small plane.

However, when Baxter and fellow instructor Ben Conner took the slender, soft-spoken Hanjour on three test runs during the second week of August, they found he had trouble controlling and landing the single-engine Cessna 172. Even though Hanjour showed a federal pilot's license and a log book cataloging 600 hours of flying experience, chief flight instructor Marcel Bernard declined to rent him a plane without more lessons.

Where was Pentagon hit?

- In section that had just undergone renovation
- Renovation had added strengthening and blast resistance
- Employees had not yet moved back in - minimal casualties
- The Pentagon presents a target of 30+ acres in roof area
- Why fly over it, and execute a perfectly level attack on the only nearly empty, blast hardened section?

Flight 77 resources

- Sites that doubt that a 757 hit the Pentagon
 - <http://home.earthlink.net/~killtown/flight77.html>
 - <http://911research.wtc7.net/talks/pentagon/index.html>
 - <http://www.cosmicpenguin.com/911/Eastman/m18h05.html>
- Sites that believe that it is likely that a 757 hit the Pentagon
 - <http://anderson.ath.cx:8000/911/pen06.html>
 - <http://perso.wanadoo.fr/jpdesm/pentagon/english.html>
- 'Agnostic' sites
 - <http://www.cooperativeresearch.org>
 - <http://www.911-strike.com/pentagon.htm>

Summary: complicity?

- Intercept: again too late, too slow, from too far away: 48 minutes from known hijack to impact
- All independent evidence of what hit Pentagon quickly seized by FBI
- The all-important fact of where the Pentagon was hit supports Pentagon complicity
- Evidence suggests something other than 757 hit Pentagon, which requires planning and total complicity

Chapter 3

Flight 93: Was it the one flight that was shot down?

“The history of our race, and each individual’s experience, are sown thick with evidence that a truth is not hard to kill, and that a lie told well is immortal.”

Mark Twain, 1835-1910

Outline of Flight 93 presentation

- The Official Story of flight 93
- Flight 93 timeline
- Evidence in support of shoot-down
- Why would a shoot-down be necessary if heroes had succeeded?

The Official Story

- Hijacked over eastern Ohio
- Target of White House or Capitol Building
- Passengers learn of WTC attacks, conclude that they have nothing to lose
- Passengers may or may not have succeeded in getting into cockpit, but in the ensuing struggle the hijackers purposely crash the plane
- As in previous three flights, NORAD was too late, too slow to intercept

Flight 93 timeline

- 8:42 am UA flight 93 departs Newark, 41 minutes late
- 9:27 am Passenger Tom Burnett calls wife, reporting a hijacking
- 9:28 am ground flight controllers hear sounds of scuffle in cockpit
- 9:34 am Tom Burnett learns of the WTC events from his wife
- 9:36 am Plane turns toward Washington
- 9:45 am FBI monitors Burnett phone call

Flight 93 timeline

- 9:57 am Sounds of fighting outside the cockpit heard on one of the phone calls
- 9:58 am One of the passengers reports that "They're doing it!" (getting into cockpit)
- 10:02 am (approx) passenger on phone to 9-1-1 in bathroom reports explosion and white smoke
- 10:03 am (official) or 10:06 am (seismic) plane impacts ground near Shanksville, PA

More detailed timeline

From takeoff to takeover

PUTTING IT ALL TOGETHER

This timetable is approximate, based on a typical Newark-San Francisco Boeing 757 flight and information gathered from various sources, including passengers' families, air traffic reports, news reports and witnesses on the ground. A typical routing would take Flight 93 over Cleveland. Somewhere over Western Pennsylvania and eastern Ohio, the hijackers made their move and turned the plane around.

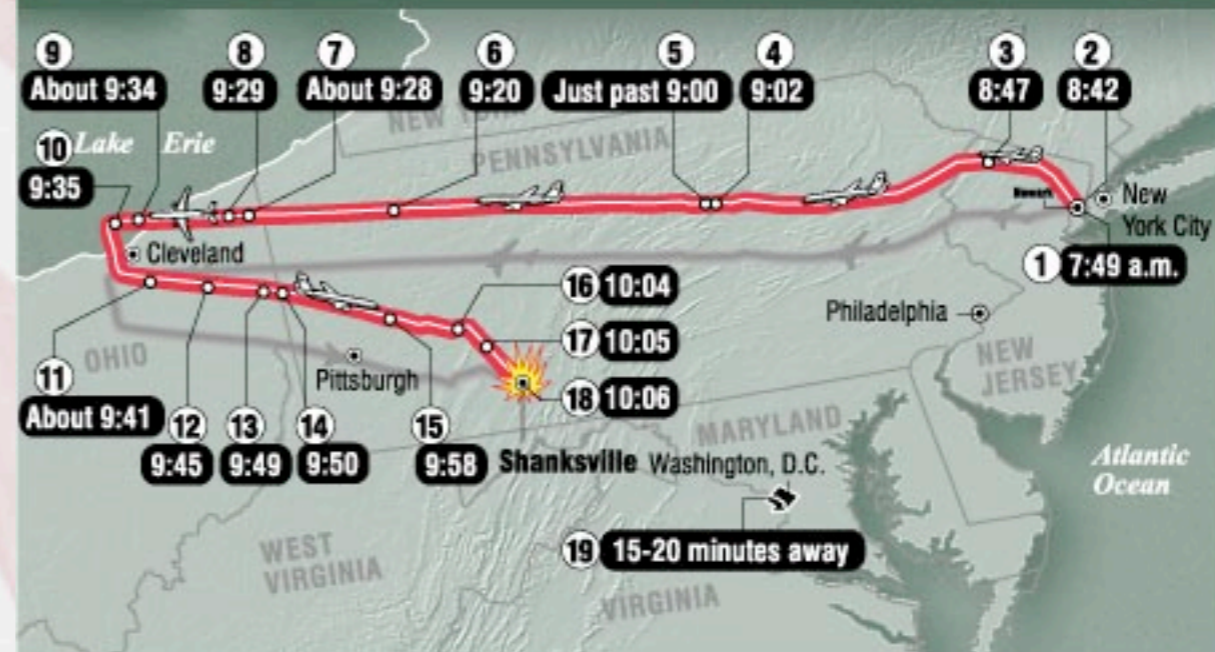

- 1 7:49 a.m.**
Mark Bingham calls friend. Says that he is sitting in first class and drinking orange juice.
- 2 8:42 a.m.**
United Airlines Flight 93 departs from Newark International Airport in New Jersey, 41 minutes late.
- 3 8:47 a.m.**
Plane passes through 10,000 ft.
- 4 9:02 a.m.**
Plane reaches cruising altitude of 31,000 feet. Estimated cruising speed is 515 mph, but actual speed on this flight may have varied.
- 5 Just after 9 a.m.**
United warns all aircraft of the potential for cockpit intrusion and to take precautions to barricade cockpit doors.
- 6 9:20 a.m.**
Hijacking begins. Tom Burnett calls wife, reports takeover.
- 7 9:28 a.m.**
Keyed microphone reveals someone in cockpit saying, "Get out of here!"
- 8 9:29 a.m.**
Jeremy Glick calls his wife and describes the hijackers. He is told about the attacks in New York.
- 9 9:34 a.m.**
Cockpit intercom: In broken English, a man announces there is a bomb and that the plane is returning to the airport.
- 10 9:35 a.m.**
Hijacked plane is turned around near Cleveland.
- 11 9:41 a.m.**
Marion Britton calls friend. She tells him that two people have been killed and the plane has been turned around.
- 12 9:45 a.m.**
Todd Beamer's cell phone call is transferred to Verizon operator Lisa Jefferson. He tells her about the passengers' plan to fight the hijackers.
- 13 9:49 a.m.**
Pittsburgh International Airport flight tower is evacuated.
- 14 9:50 a.m.**
Sandra Bradshaw calls her husband. She tells him that they are in the rear galley filling pitchers with hot water to use against the hijackers.
- 15 9:58 a.m.**
• Todd Beamer's call ends as he and others begin to carry out their plan to force their way into the cockpit and take over the plane.
• CeeCee Lyles has called her husband. Screams and jumbled noises heard in the background. Call disconnects as confrontation with hijackers begins.
- 16 10:04 a.m.**
Johnstown-Cambria County Airport reports the plane is 15 miles south and coming fast.
- 17 10:05 a.m.**
People on the ground witness the plane flying low and erratically.
- 18 10:06 a.m.**
Flight 93 crashes near Shanksville, approximately 80 miles southeast of Pittsburgh.
- 19 15-20 minutes away**
Possible terrorist target: Washington D.C. approximately 124 miles, or 15-20 minutes, from crash site.

Was flight 93 shot down?

- Phone call in which the woman reported "They're doing it!" ends with whooshing sound
- Newspaper report of the cockpit voice recorder said that sound of wind was last thing heard on recording
- FBI has stated that claims of a bomb aboard were false - so where did wind noise come from?
- Sound of explosion and smoke reported by lavatory caller are strong evidence of shoot-down

Witness statements support shoot-down conclusion

- Nashua flight controller said that F-16 was tailing flight 93
- Small, unmarked white military-style jet seen just before crash
- Some witnesses reported hearing sound of air-to-air missile
- Other witness reported hearing thumps, followed by loss of engine noise, then sound of crash
- F-15 pilot reported statement that fourth plane had been shot down

Debris trail supports shoot-down conclusion

- Airframe was 'obliterated' at main crash site
- Half-ton piece of engine found more than a mile away from point of impact
- Debris found up to eight miles away
- Debris "rained down" on Indian Lake Marina, two and a half miles from crash site
- Why would debris be anywhere but around the impact site unless the plane had broken up in the air?

post-gazette.com

PG News

Pet Tales

with Linda Wilson Fuoco



PG Home

PG News

Sports

Lifestyle

A&E

Photo Journal

AP Wire

Business

Classifieds

Web Extras

Nation & World

Sports

Local News

Health & Science

Neighborhoods

Lifestyle

Business & Technology

Opinion

Investigators locate 'black box' from Flight 93; widen search area in Somerset crash

Thursday, September 13, 2001

By Tom Gibb, James O'Toole and Cindi Lash, Post-Gazette Staff Writers

Investigators this afternoon discovered the "black box" containing flight data recordings from United Flight 93 at the crash site in rural Somerset County.

as they widened their search area today following the discoveries of more debris, including what appeared to be human remains, miles from the point of impact at a reclaimed coal mine.

Residents and workers at businesses outside Shanksville, Somerset County, reported discovering clothing, books, papers and what appeared to be human remains. Some residents said they collected bags-full of items to be turned over to investigators. Others reported what appeared to be crash debris floating in Indian Lake, nearly six miles from the immediate crash scene.

Official statements support possible shoot-down conclusion

- At 9:56 am fighter jets were given orders to shoot down any aircraft under control of hijackers
- Shortly after the order was given, Cheney was asked whether to engage
- Cheney gave affirmative answer several times
- When Bush heard about the loss of flight 93, he asked, "Did we shoot it down, or did it crash?"
- Paul Wolfowitz later said that the military was in position to bring it down if necessary

Cover-up

- FBI confiscated tape of call to 9-1-1 dispatch describing explosion
- 9-1-1 dispatcher was barred from being interviewed
- Conflicting official accounts of when shoot-down was authorized
- Missing 3 minutes at the end of the cockpit voice recorder tape

Flight 93 resources

- <http://www.flight93crash.com/>
 - Most complete collection of data on Flight 93
- <http://www.enterstageright.com/archive/articles/1001/1001flight93.htm>
 - this is from Stuart Buck, a conservative commentator who questions the Flight 93 story

Conspiracy theory time: why shoot down flight 93?

- If the hijacking had been successfully foiled, there was a commercial pilot on board who could have flown the plane
- If the hijackers had lived there might be some exposure of involvement by intelligence agencies in running the operation
- A successfully aborted hijacking might have exposed inconvenient details about the way the operation was carried out

Chapter 4

The President's behavior: why did he act as he did?

“Every great mistake has a halfway moment, a split second when it can be recalled and perhaps remedied.”

Pearl Buck, 1892-1973

Timeline of President Bush's actions

- 8:46 am Flight 11 crashes into WTC 1
- 8:48 am CNN breaks regular programming to report crash
- before 9:00 am Ari Fleischer learns of crash en route to Booker Elementary School
- 9:00 am Motorcade arrives at school, and White House Situation Room Director Deborah Loewer runs over to tell Bush
- 9:00 am Bush confers with Condoleeza Rice via telephone
- 9:03 am President Bush enters class room to read to children
- 9:05 am (approx) Andrew Card informs the President of second plane crash
- 9:16 am Bush leaves classroom to confer with advisors
- 9:29 am President Bush delivers television address

What's wrong with this picture?



- Presidents travel with an unrivaled electronic communications center
- It is extremely likely Bush knew of first WTC impact en route to school
- By the time he conferred with Rice at 9:00 am, three hijackings were in progress
- Andrew Card's famous whisper in Bush's ear: so few words were said that it is hard not to think that Bush already had an understanding and Card's words were merely confirmation

What's wrong with this picture?

- In a period when multiple hijackings were in progress, Bush went ahead and did the photo-op with children
- After he is personally informed of the second crash by Andrew Card he still sits in the classroom for a full twelve minutes
- After reading the story about the pet goats, Bush was still in no hurry - one account refers to him as the “dawdler-in-chief”
- After leaving the classroom, he went ahead with the planned television address at the scheduled time and place

A startling admission by Dick Cheney

- Dick Cheney, in an interview on Meet The Press on Sept. 16th, 2001, admitted that "the Secret Service has an arrangement with the FAA. They had open lines after the World Trade Center was..."
- Cheney stopped in mid-sentence, perhaps realizing how damaging what he was saying was
- This implies that the FAA likely kept the Secret Service informed of the status of the attacks as they unfolded

Why is when the President knew important?

- President Bush showed an amazing amount of unconcern about his role of commander in chief
- When he finally went to the Sarasota airport and took off, no fighter jet escort was ordered
- How could he assume that he would not be a target as well?
- There are SEVEN different accounts of how Bush learned of the crashes in New York city, all told by different administration officials
- The common theme in all accounts is that no one, least of all President Bush, realized the extent of the unfolding tragedy

The strange issue of Bush's recollection of the first plane crash

- On more than one occasion, President Bush has stated that he saw the first plane hit the Tower before he went into the classroom, remarking, "There's one terrible pilot."
- However, there was no footage of the first crash broadcast on September 11th - the Naudet brothers' film was not broadcast until 13 hours later
- Some have speculated that the only way he could have seen the first crash was if intelligence agencies had been expecting it and had filmed it as it happened

Complicity?

- The behavior of President Bush and the secret service seem to imply that the scope of the attacks was known beforehand
- If Bush really did see the first plane crash before going into the class room it implies that the White House knew precisely when and where the attacks were going to occur
- Either the Secret Service was incredibly inept, or it was known that they and President Bush were not at risk

Unanswered questions for chapters 2, 3, and 4

- How could flight 77 fly unmolested for three-quarters of an hour before striking the Pentagon?
- Why were the videos from the Sheraton Hotel and the gas station seized within minutes of the crash, and what would they show?
- Why did some Pentagon employees report smelling cordite, an explosive?
- Why has the FBI not released the black boxes from flight 77 to the NTSB for analysis?

Unanswered questions for chapters 2, 3, and 4

- When precisely was the open line between the FAA, NORAD, and the Secret Service opened, and what was discussed as the attacks unfolded?
- It is rumored that a National Guard F-16 was in the vicinity of Flight 93, and may have shot it down; what planes were enroute or in the area?
- Why did one of Flight 93's engines fall so far from the impact site?
- When precisely did President Bush learn of each of the hijackings, and why did he take literally no action?

So, what can you do?

An ounce of action is worth a ton of theory.

- *Friedrich Engels 1820-1895*

- Write to the National Commission on Terrorist Attacks upon the U.S. (aka Kean Commission)
 - <http://www.9-11commission.gov/>
 - 301 7th St. SW, Room 5125, Washington, DC 20407
- Call or write your senator and representative
 - Find your senator or representative by going to <http://www.congress.org/>

So, what can you do?

- Write a letter to your hometown newspaper raising questions that are not being addressed by the Kean Commission
- Join an action-oriented organization like the one at <http://www.911visibility.org>
- March in the streets with signs questioning the official story
- Host an evening presentation for friends and family featuring Barrie Zwicker's video, "*The Great Deception*"
 - <http://www.viewerplus.com/Splash.asp?Stat=Vision>